

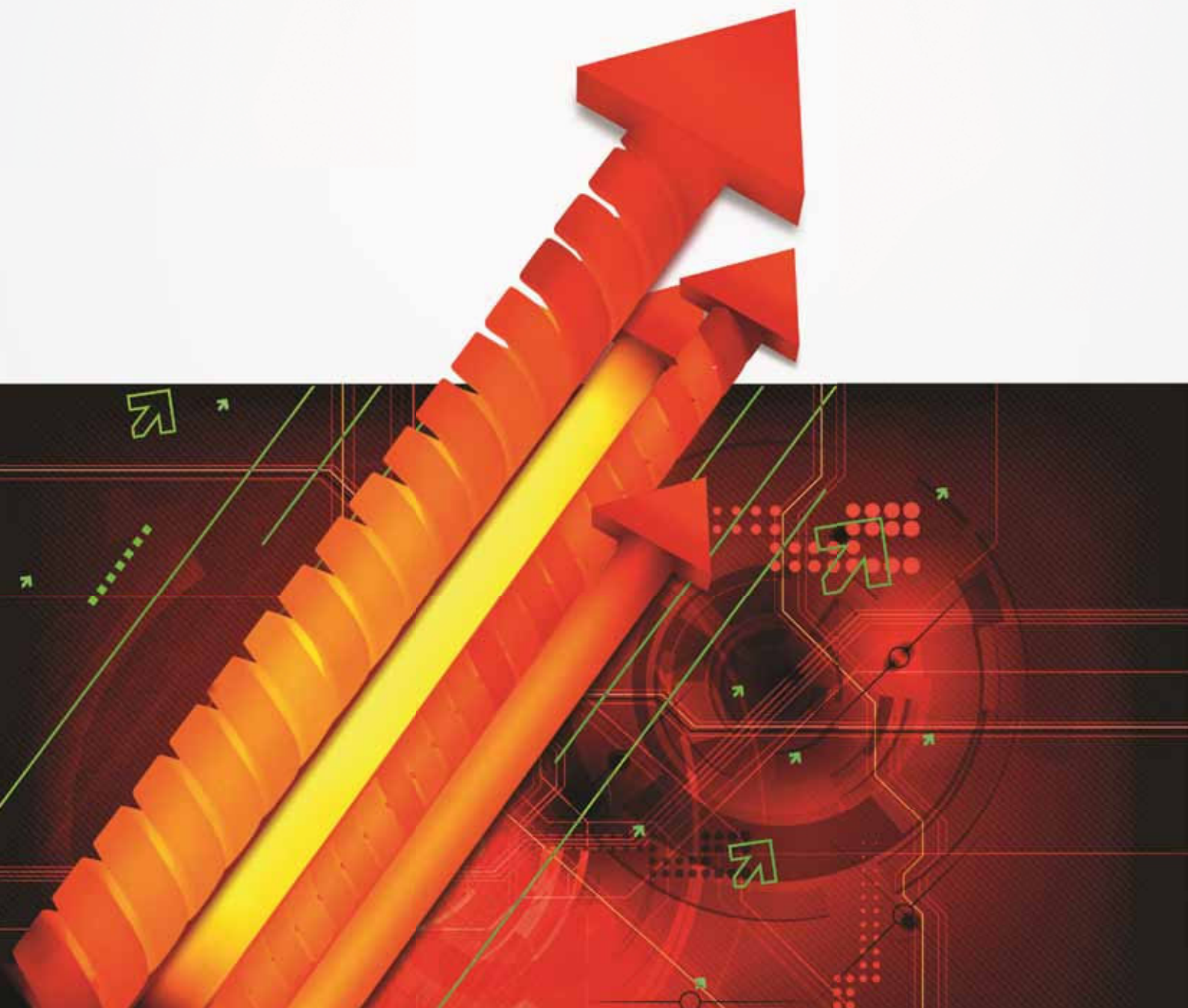

---

**T H E P O W E R T O**  
**S U R G E A H E A D**

---



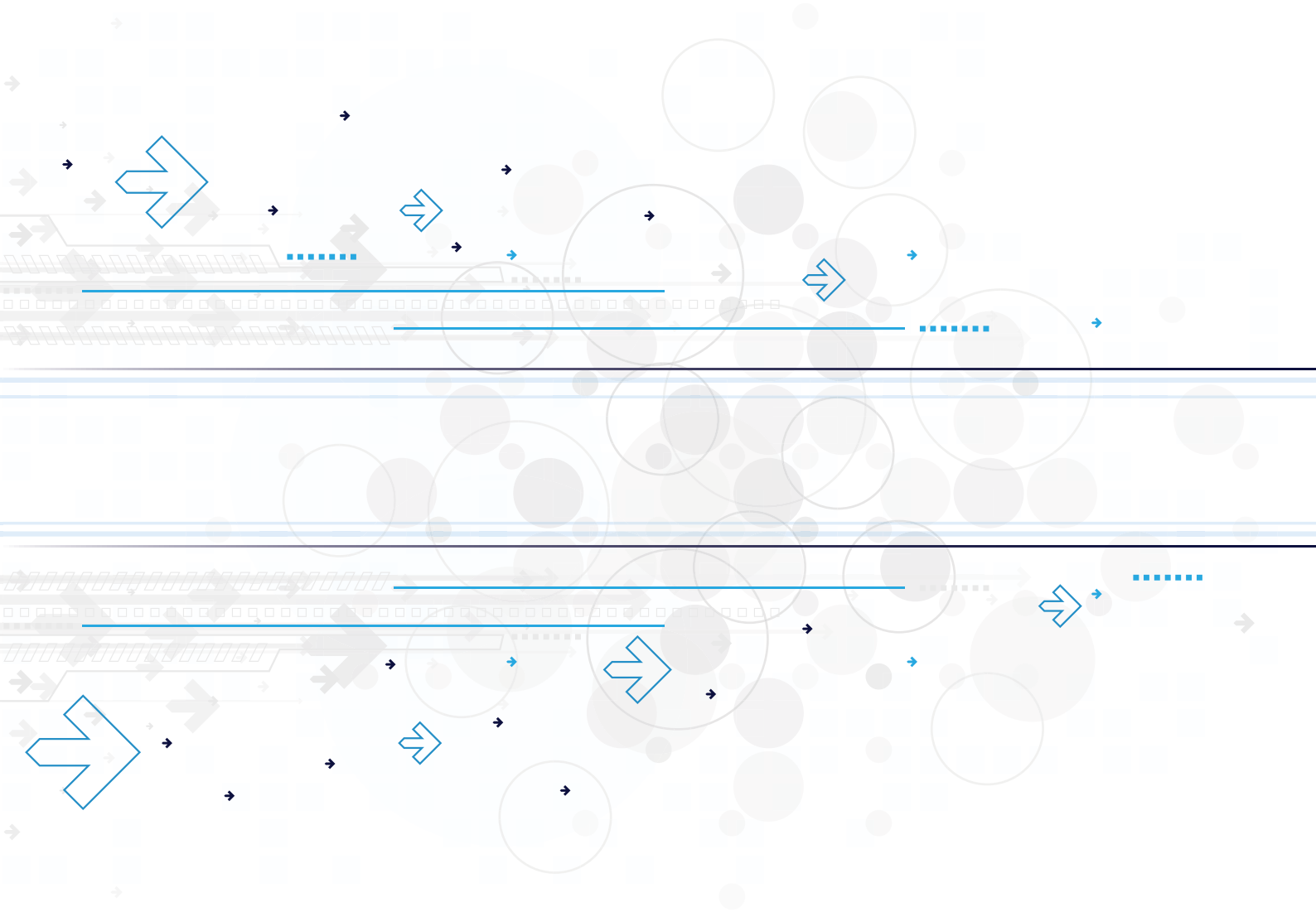

# THE COMPANY

## SILCARB



♦ Silcarb, An ISO 9001-2008 Company is India's premier indigenous manufacturer of Silicon Carbide Heating Elements, with its plant located at Bangalore, South India.

♦ Silcarb's 'ALPHA ROD' Silicon Carbide Heating Elements Series is made of Re-Crystallized Alpha Silicon Carbide.

♦ Silcarb's 'SPIROHEAT' Silicon carbide heating element are made of Reaction bonded Silicon Carbide.

♦ 'Alpha Rods' and 'Spiroheat Elements' are available in different Configurations for connections from two ends or from one end.

# AN INTRODUCTION TO 'ALPHA ROD' ELEMENTS

## TECHNICAL DATA

### GENERAL DESCRIPTION

The Alpha Rod Element is a resistance type silicon carbide element. The elements are thick walled tubes. They have a central heating section referred to as a hot zone and two terminal sections called cold ends. The cold ends are impregnated with silicon metal to lower their resistance, and allowing them to operate at a lower temperature.

The extremities of the elements are metalized with aluminium to provide a low resistance contact surface to which the electrical connections are made with braided aluminium straps. Elements are described by giving the overall length, the heating section length, the diameter and resistance.

### SILICON CARBIDE HEATING ELEMENT

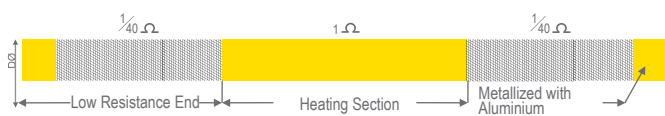

### HIGH PERFORMANCE

The Alpha Rod Elements will give you superior performance due to their high density of 2.4gms/cc (or higher). This gives the element very slow aging characteristics and additional strength.

### OPERATING TEMPERATURES

The Alpha Rod Elements can be operated at furnace control temperatures up to 1550°C in an air atmosphere, or inert atmospheres of argon or helium. In reducing atmosphere the maximum recommended operating temperature is 1350°C.

---

## CHARACTERISTICS OF ALPHA ROD ELEMENTS

---

The Alpha Rod element is a linear type resistance heater that converts electrical energy to heat energy (Joule's Law  $W=I^2R$ ). W=power in watts, I=current in amperes, R=resistance in ohms.

The heating elements are often referred to as self-bonded, for the lattice structure or bonds that hold the elements together that are formed by recrystallizing the silicon carbide at very high temperatures. The elements are manufactured of green silicon carbide which is classed as an excess electron type semi-conductor. The resistance of a silicon carbide element is difficult to measure at room

temperature due to minor impurities, self heating, and contact resistance. Also silicon carbide has a negative resistance temperature characteristic from room temperature to approximately 800°C.

It turns positive at this point and remains so throughout its normal operating temperature range. A typical resistance temperature characteristic curve of a silicon carbide heating element is shown in Fig.C. Nominal element resistance is measured at a standard calibrating temperature of 1050°C. Resistance Values of elements are shown on the physical and electrical characteristics pages.

---

## SERVICE LIFE

---

The Alpha Rod heating elements increase gradually in resistance with use. This characteristic of increasing in resistance is called aging. Aging is a function of the following

- ♦ Operating temperature.
- ♦ Electrical Loading – Usually

Expressed in watts per square centimetre of element radiating surface. ♦ Atmosphere. ♦ Type of operation (Continuous or intermittent) ♦ Operating and Maintenance Techniques.

---

## MOUNTING

---

There are no restrictions on the mounting positions of Alpha Rod Elements, although the horizontal and vertical positions are the more common. Extreme caution should be used when mounting to insure that the elements are not placed in tension. There should be adequate freedom to allow for the furnace and elements to expand and contract independently. When mounting elements vertically they must be supported on the lower end by electrically insulated supports.

Alpha Rod Elements should have their heating sections centered in the furnace chamber so that no portion of the heating section extends into the furnace wall. A conical or truncated cone shaped recess ½ inch deep is located on each interior wall where the element passes through. This allows the hot zone to radiate properly and helps maintain a uniform temperature in the kiln.

# TYPES OF ALPHA RODS

## THREE PIECE ALPHA ROD

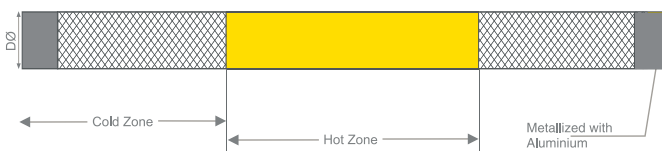

Three piece Alpha Rod features welded low resistance (LRE) cold ends which run cooler than any one piece cold ends. Heat is concentrated in the furnace, not the ends, for energy efficiency. Maximum Temperature 1550°C.

Silcarb has one of the highest Hot: Cold ratios of 1:40, which makes it one of the most energy efficient silicon carbide heaters.

# ALPHA RODS

## TYPE 'U'

---

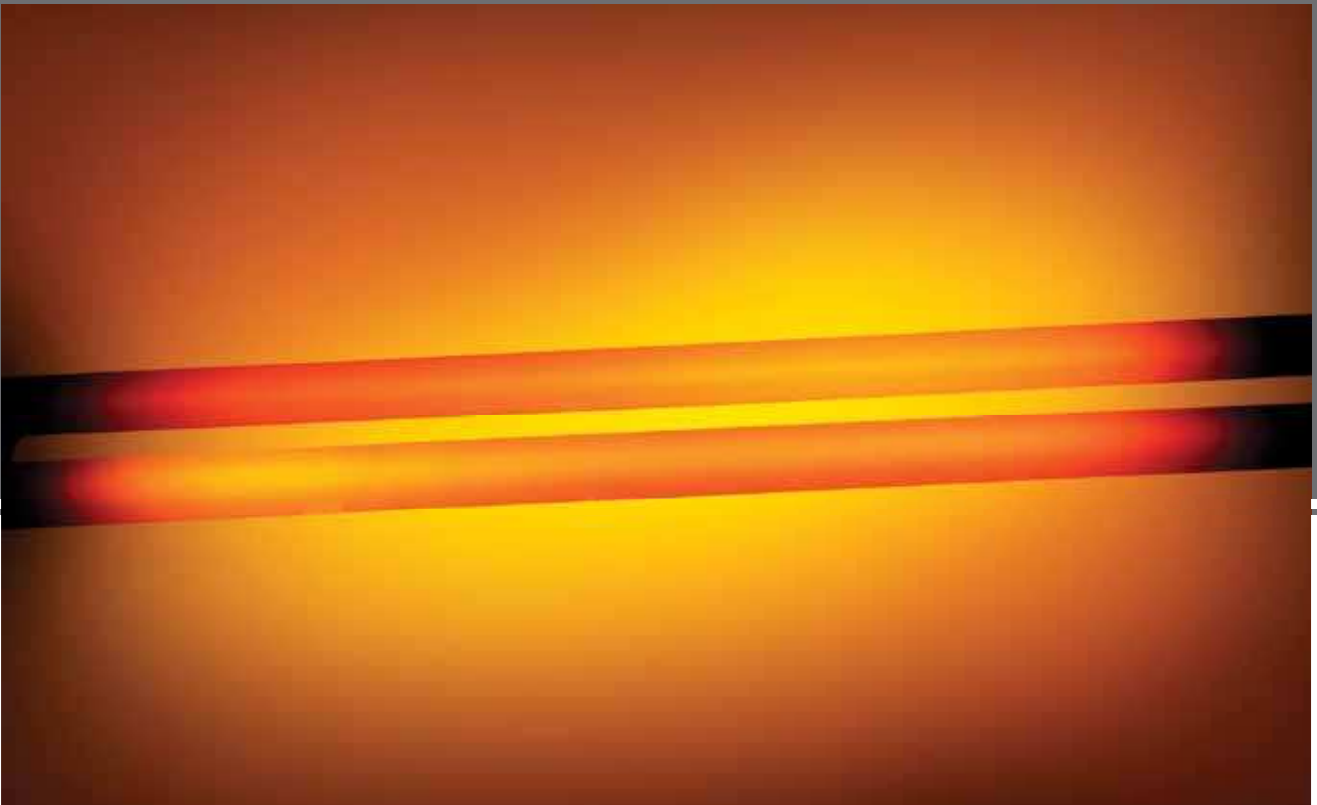

The 'U' Shaped Alpha Rod comprises of two carefully matched sic rods united with a Thickend Bridge, both terminals from one side of the furnace. Ideal for drop-through design, radiant tube systems or where one element

will not span the heating chamber. Pictured : Type U element with straight cold end. Dumbbell cold end are also available (For Dimensions, Resistance, Kindly Contact us):



# OXIDE COATED ALPHA ROD

---

The Alpha Rod Silicon Carbide Element is coated with an oxide layer on the Hot Zone. This Oxide coated Alpha Rod



reduces surface oxidation of the Element and thereby gives a long and stable life, working under harsh conditions.

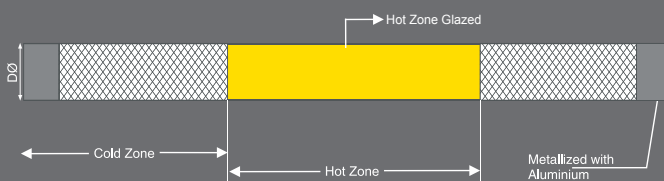

# SPIROHEAT ELEMENTS

---

Spiroheat elements are made from thin walled tubes of Alpha Silicon Carbide, which are dense and resistant to oxidation. Spiroheat elements operate in most industrial and laboratory furnaces at temperatures upto 1600oC. Spiroheat elements being a thin walled, fine grain form of reaction



bonded Silicon Carbide, will withstand very rapid heating and cooling cycles, severe thermal shocks, and high Electrical loadings. The spiroheat range of elements are available in different product forms to suit a variety of heating processes.

---

## TYPE DE ELEMENTS

---

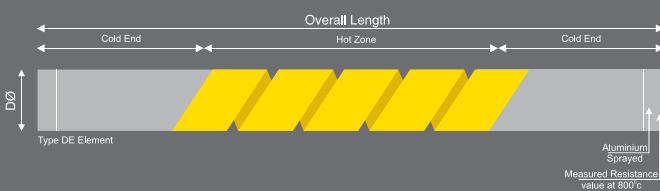
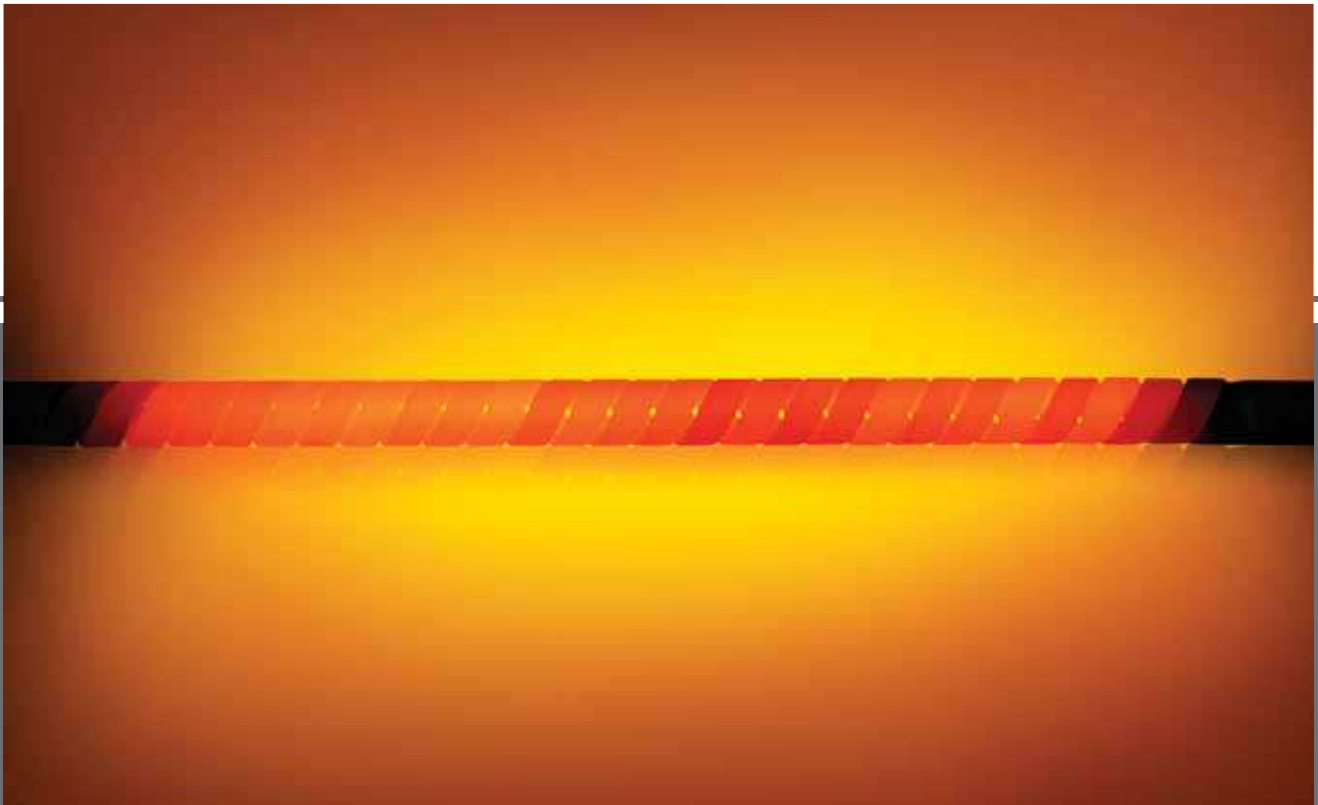

# T Y P E S E E L E M E N T S

---

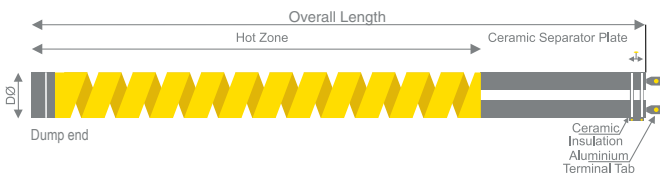
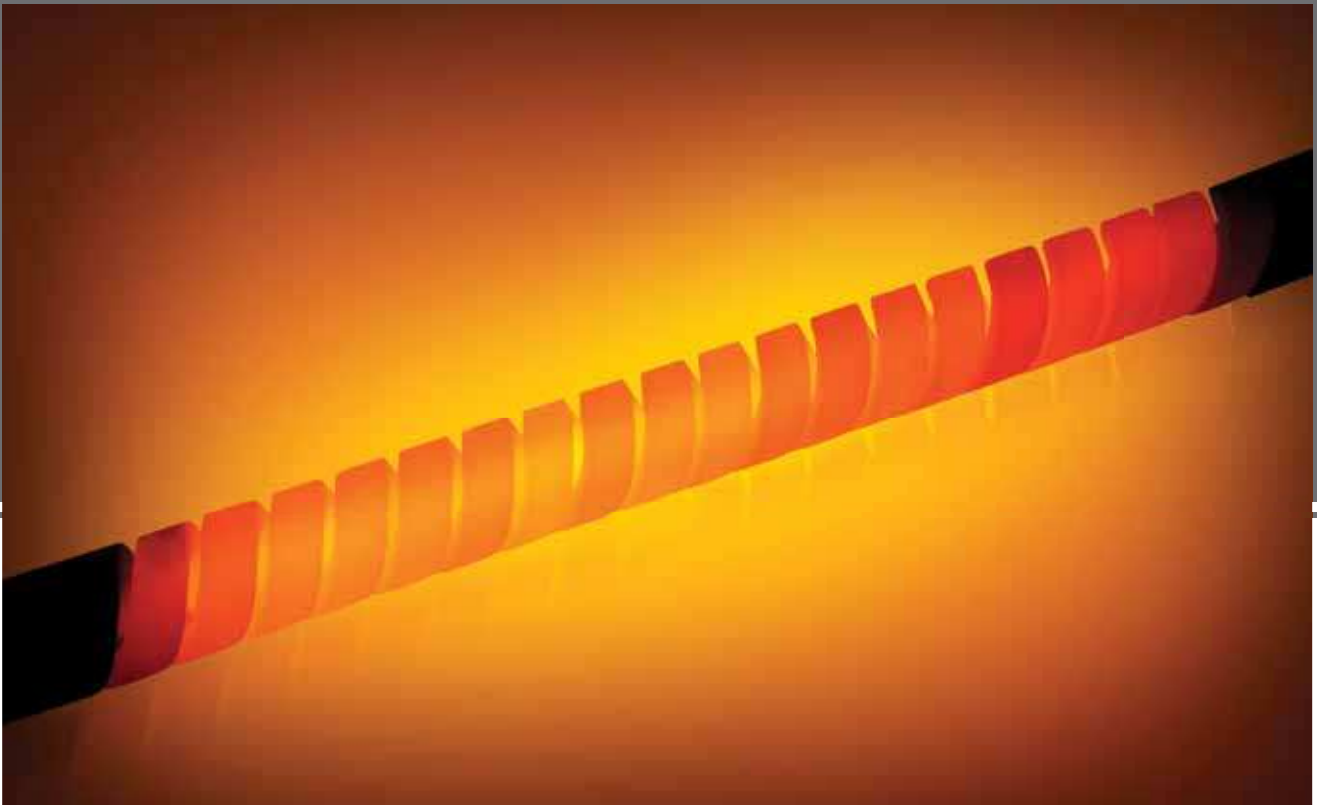

Spiroheat Single Ended Elements have all terminal connections at one end. These Single Ended Elements are made of Reaction Bonded Silicon Carbide.

Typical density of Spiroheat Elements are 3.3 Gms./cc – 3.4 Gms./cc. These are ideally, where furnace access is limited to any one plane.



# D U M B E L L

## A L P H A R O D

---

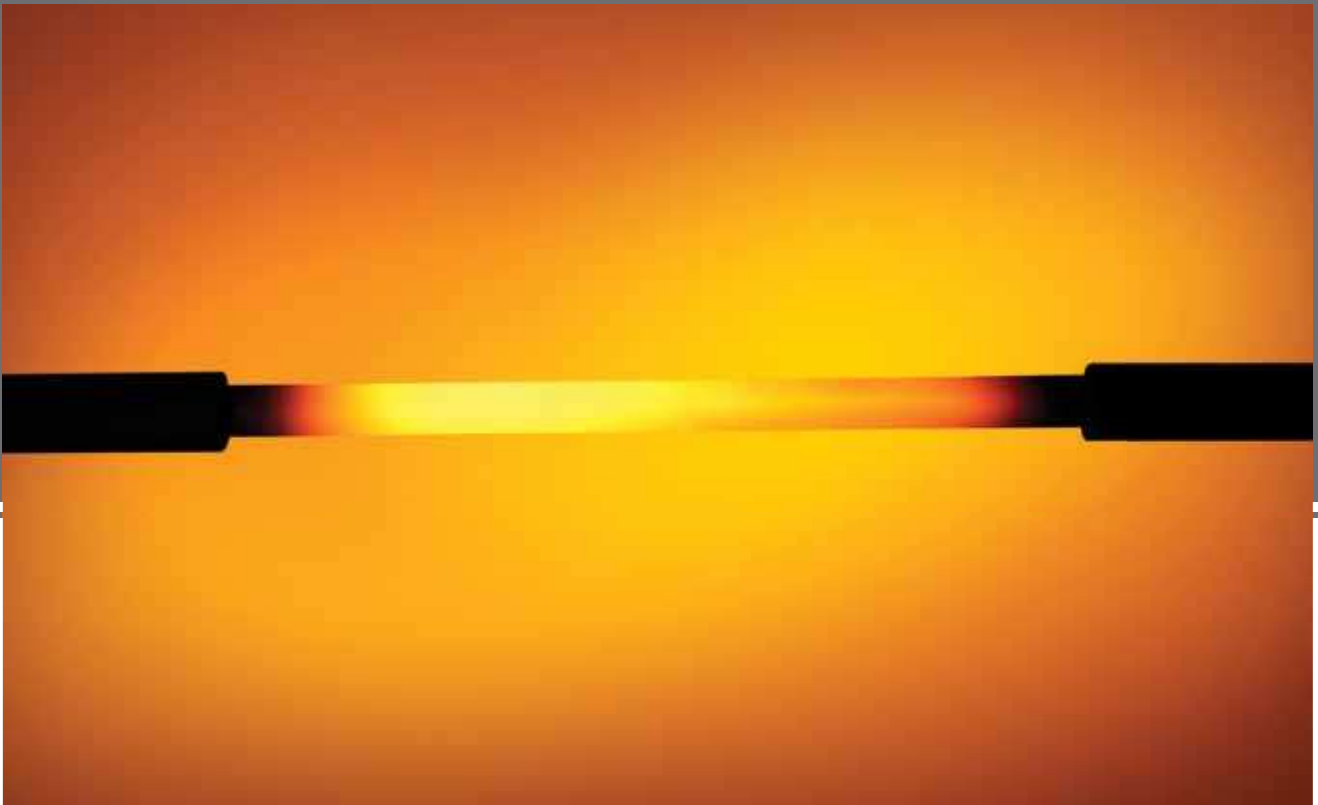

One of the earliest heating element designs, the enlarged cold ends of the Dumbbell style element were originally made with oversized cold ends to increase cold end cross section, lowering electrical resistance, thereby lowering cold end operating temperatures. Modern Dumbbell Alpha Rod by contrast,



cool by virtue of the decreased resistivity of the lower resistance cold end material used in the manufacturing process. Over size cold ends are therefore no longer necessary, the old style resistance ratio was 1:3, whereas the new DB resistance ratio is 1:40. Maximum temperature is 1550°C. (For Dimensions, Resistance, Kindly Contact us):

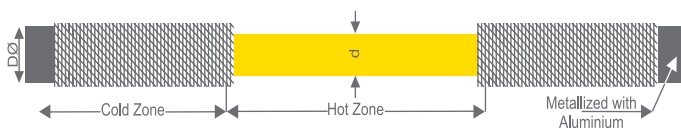

## ORDERING WITH SILCARB

**ORDERING :-** Alpha Rod Elements are specified as follows :  
Diameter / Hot zone length / Overall length / Nominal resistance.

**ORDERING Type SE Elements** are specified as follows:  
Diameter / Hot zone length / Overall lengths / Nominal

resistance. Spiroheat Type Double End elements can also be provided with offset Hot zones i.e., unequal cold end lengths and also split hot zones for central support in exceptionally long hot zones. Please specify your exact requirements. Preferably with drawings while ordering. Closer tolerances on resistance can be supplied at Special rates.

## ELECTRICAL CHARACTERISTICS OF 'SPIROHEAT / ALPHA ROD ELEMENTS

The resistance of spiroheat / Alpha rod Element varies with temperature as detailed in the figure below. From relatively high value at room temperature it falls to a minimum at about 800°C and then gradually rise upto its maximum operating temperature.

The resistance value at 1400°C will approximately be 10% more than its value at 800°C. The voltage across the element and the current passing through it should be measured at about 800°C to determine the resistance ( $V=IR$ ).

Mean Furnace Temperature (Degrees Centegrade)	1500	1450	1400	1350	1300
Maximum Surface Loading (W/cm <sup>2</sup> )	3	4	4	5	6

## OPERATING TEMPERATURES

Spiroheat / Alpha Rod elements may be operated in air at furance temperature of upto 1550° C. Elements may also be used in neutral or reducing atmosphere but a lower temperature limit may be required. Maximum recommended operating temperatures for Spiroheat / Alpha Rod Elements in various process atmospheres.

Atmosphere	Maximum Element Temperature (°C)	Comments
Air	1550	
Vacuum	1000	Depends on degree and period of application. Use unglazed elements for extended use in vacuum
Pure Nitrogen	1050	
Hydrogen	1200	Unglazed elements may be required
Exothermic Gas	1250	
Endothermic Gas	1250	
Hydrocarbons	1250	Periodic burn - off of carbon deposition may be required

Note that element temperatures are quoted and that these may be Considerably higher than the furnace temperature

## ELEMENT LOADING

The operating temperature of the elements is dependent on both the furnace temperature and the specific element loading, normally expressed in watts per square centimeter of the Hot zone area.

## RESISTANCE/TEMPERATURE CHARACTERISTICS

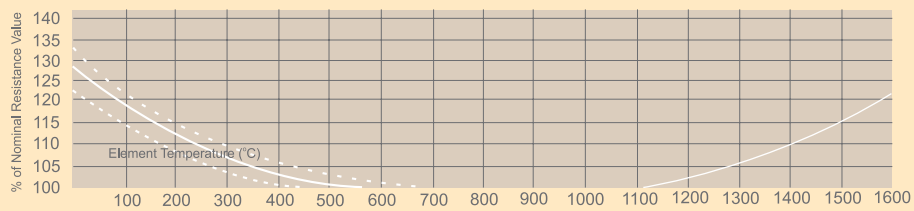
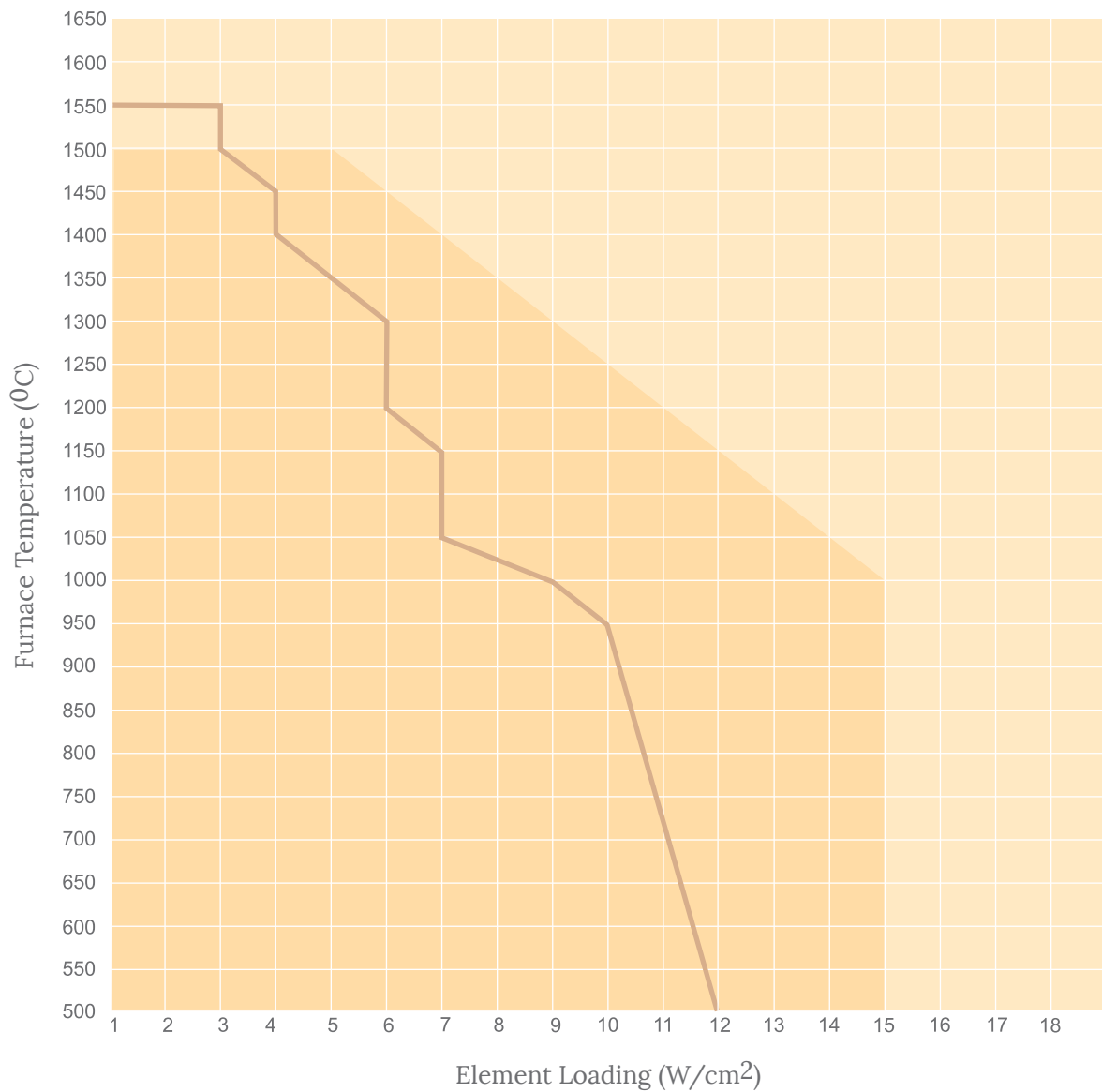

Figure - C



---

## EFFECT OF ATMOSPHERES

---

Spiroheat / Alpha Rod elements are normally operated in air or other oxidizing atmospheres, as other gases may react with the element material or the protective glaze, thereby causing a reduction in element life. It is recommended that the manufacturer be consulted if the use of Spiroheat Element in a reducing atmosphere is being considered.

Water vapour has a serious effect on 'Spiroheat / Alpha Rod Element', by increasing, the oxidization of the material and hence the ageing rate. Furnace should be thoroughly dried before the elements are installed but if it is essential to use the elements for drying, then the furnace should be well ventilated and no build up of steam should be allowed to occur.

Other process vapours may also adversely affect element life, either by chemically attacking the silicon carbide and the protective glaze or by condensing in the element support holes causing restriction and subsequent breakage. Most alkali vapours will have a detrimental effect, halogen gases, metal halides (e.g. Fluxes in aluminum furnaces) and also most of the metallic oxides.

To minimize any attack an efficient extraction system should be incorporate to reduce the volatile concentration in the chamber to an acceptable level. This will also encourage an inflow of air over the element cold ends and minimize any condensation at these points.

---

## INSTALLATION METHODS

---

The elements must be accurately positioned in the furnace to ensure that the hot zone does not enter the element support holes. It is important to ensure that elements are

free to move in all directions and mounting holes must be aligned and sufficiently large to prevent restriction, for expansion during hot condition.

---

## TYPE DE/ALPHA ROD ELEMENTS

---

Special lead-in sleeves are available for each size of element. They should be fitted from the outside of the furnace in holes bored to a diameter which will ensure a loose fit. Sleeves should never be cemented into position. If sleeves are not used then the element support holes should be about 3-6mm large than the element diameter for sizes up

to 18mm about 8-10mm for larger sizes. For exceptionally thick furnace lining and where there is a possibility of volatiles condensing on the cold ends, a fairly large hole diameter should be used and the elements centralized by supporting them on a small ceramic fiber pad under cold end.

## TYPE SE ELEMENTS

Special lead-in sleeves are recommended for use with SE elements to provide the correct alignment and support required. These sleeves should be of a loose fit and not cemented into positions. Type SE Elements can be mounted horizontally or vertically, projecting up or hanging down. The terminal assembly should be outside the furnace structure to keep it as cool as possible. No Portion of the spiral heating section should extend into the refractory wall. The element should be mounted in a high Die-electric lead-in sleeve to prevent possible shorting of the terminal

ends, because full element voltage exists along the entire length of the Terminal.

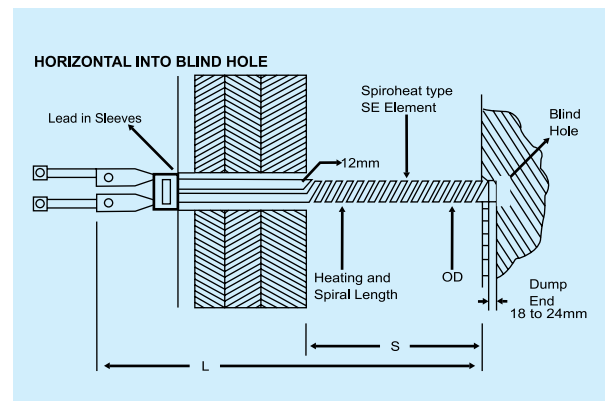

## INSTALLATION AND MAINTENANCE

- ♦ The correct size of elements should be chosen at the design stage of the furnace. This is to ensure that the wattage loading does not exceed that shown in the Element Loading graph.
- ♦ The element support holes must be of the right size, i.e. 3 to 6 mm larger than the element diameter upto 18 mm and 8-10 mm for larger sizes and should be installed along with ceramic lead-in sleeves for both type DE & SE Elements.
- ♦ The aluminium braid connections should be flexible and long enough to avoid any stress on the elements.
- ♦ Connecting spring steel clips tend to loose their tension over a period of use. Therefore, new clips should be used when ever an element is replaced.

- ♦ when elements are connected in series it must be ensured that they are well matched in resistance. Generally not more than 2 elements should be connected in series.
- ♦ If an element breaks prematurely due to mishandling it may be replaced with a new one. However, if the furnace has been run for a long period, it is preferable to replace the full set of elements owing to the incompatibility of resistance due to ageing. Partially aged elements may be stored for later use with others of the same resistance.
- ♦ When starting with new elements always select the minimum voltage tapping available.

- ♦ When an element is used continuously as in the case of a tunnel Kiln, special glaze treatment is required. Please specify use while ordering. It is recommended that a chart of the elements resistances be maintained and the resistance values of the elements operating be entered every 15days. This helps to monitor the life of the elements.

- ♦ As these elements are fragile, handle with care, particularly whilst fitting the braids and clamps.



- ♦ Block off the annular space between the element and the surrounding refractory with ceramic fibre or glass wool to prevent heat loss at the cold ends.

## ACCESSORIES

Silcarb manufactures a range of element connections To suit its Spiroheat / Alpha Rod Elements.

- ♦ Connecting Braids – Aluminum Braid is recommended for making all element connections because of its high conductivity, flexibility and resistance to oxidation at high temperatures.

- ♦ Terminal Clips: Alpha Rod / Spiroheat type DE & SE elements are supplied with complete terminal Accessories including lengths of aluminium braid for connection to the power supply. In a majority of applications where the terminal ends are well ventilated and unlikely to exceed temperatures of about 250°C, connections are made by

wrapping the aluminium braid around the terminal end and securing with Type H spring clips, and are fitted manually.

Silcarb recommends that terminal clips should be changed with the element as the clips tend to lose their tension over a period of time.



- ♦ Special lead - in sleeves can also be provided along with the elements. The inner and outer diameters of the lead - in sleeve are fixed depending upon the diameter of the element. However the length of the lead-in sleeve, depend upon the insulation thickness of the furnace. While ordering please mention length of the lead- in sleeve necessary for your requirements

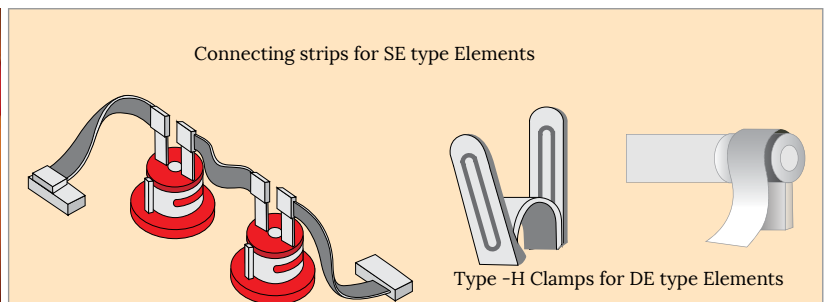
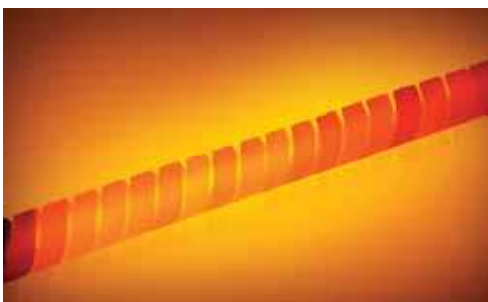

## POWER INPUT

A variable voltage source is necessary to provide power input to the heating elements to offset the drop in rating due to the aging of the elements with use. A transformer (tapping or continuously variable) or a thyristor drive would serve the purpose. However, it is recommended that a 100% voltage reserve be provided to ensure the maximum life

from the heating elements. In case of stepped output tapping transformer, it should be ensured that adequate taps are provided. It is recommended that a minimum of 8 Stepped outputs or taps be provided to ensure that the elements are not drastically overloaded While changing from one tap to the next higher one.

## ELEMENT SPACING

Alpha Rod / Sprioheat Element should be spaced at a minimum of  $1\frac{1}{2}$  diameters between element centres and the refractory lining. A clearance of at least 2.5 diameters should be allowed

between the element centres and the wall, but it may be necessary to increase this if uniformity of heating is required, especially if the distance between adjacent elements is large.

- A = (1.5 x D) = Minimum spacing between element centre and adjacent refractory
- B = (2.5 x D) = Minimum spacing between adjacent element centres
- C = (1.5 x D) = Minimum spacing between element centres and hearth plates or work
- D = Element Diameter

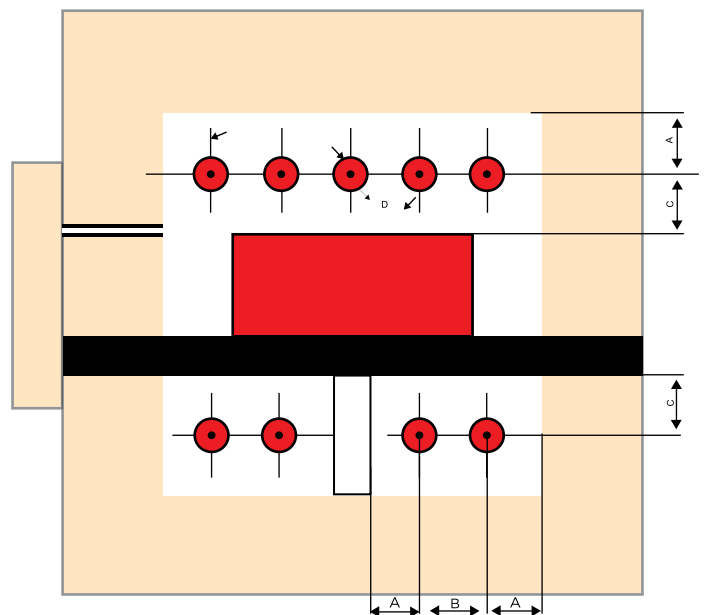
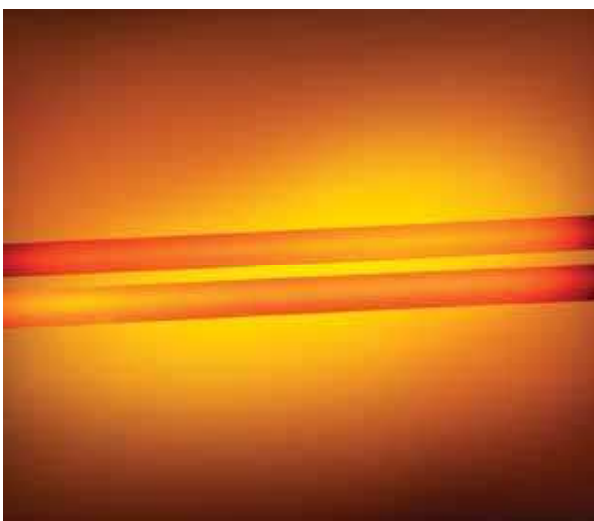

Note: if under heating is to be used, then the hearth plates should have a good thermal conductivity. Suggested material being Silicon Carbide.

<p>Silcarb today is India's leading manufacturer of Silicon Carbide Elements. Silcarb has been manufacturing heaters now in Bangalore, India for the last three decades. Silcarb is known for its high quality and fast response time to customer needs. Due to high volumes of production, Silcarb is</p>	<p>also able to price its products competitively. Silcarb is constantly innovating to reduce energy consumption for both its customers &amp; its own in-house production facilities. Environmental protection has been one of Silcarb's highest priority.</p>
--	---

**A W A R D   W I N N I N G**

WINNER OF NATIONAL AWARD FOR OUTSTANDING ENTREPRENEURS

K.L.N. FOUNDATION AWARD FOR PRODUCT EXCELLENCE

INDIAN INSTITUTE OF MATERIAL MANAGEMENT AWARD FOR ENERGY SAVING EQUIPMENT



\* Legal disclaimer - Figures and data are indicative and not legally binding on SILCARB RECRYSTALLIZED (P) LTD

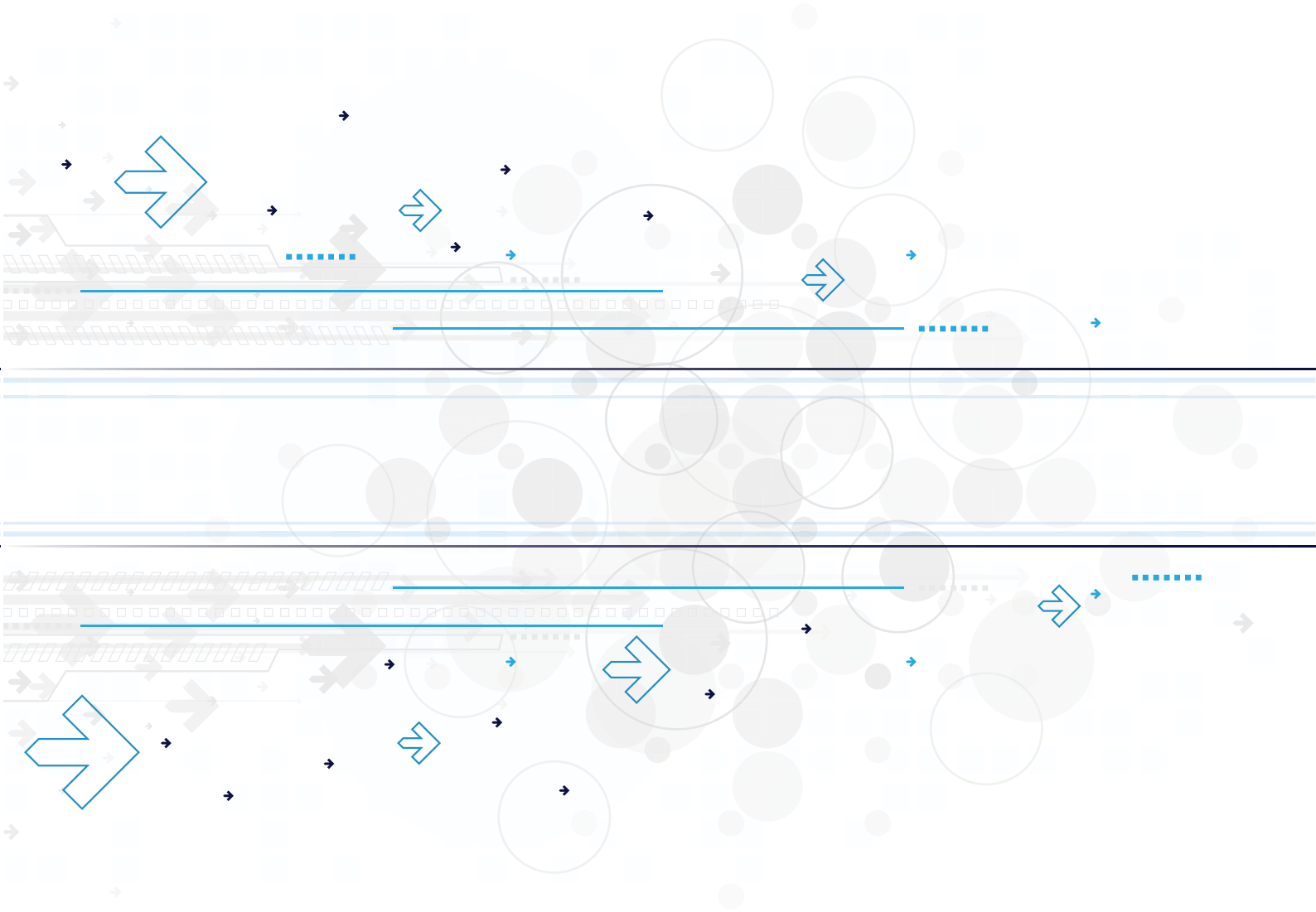



38, 17<sup>th</sup> Cross, Malleswaram  
Bangalore - 560 055, India  
Tel: +91 80 23347004 | 23462904  
Fax: +91 80 23341563 | 23312458  
Email: [silcarb@vsnl.com](mailto:silcarb@vsnl.com)

---

[www.silcarb.com](http://www.silcarb.com)